

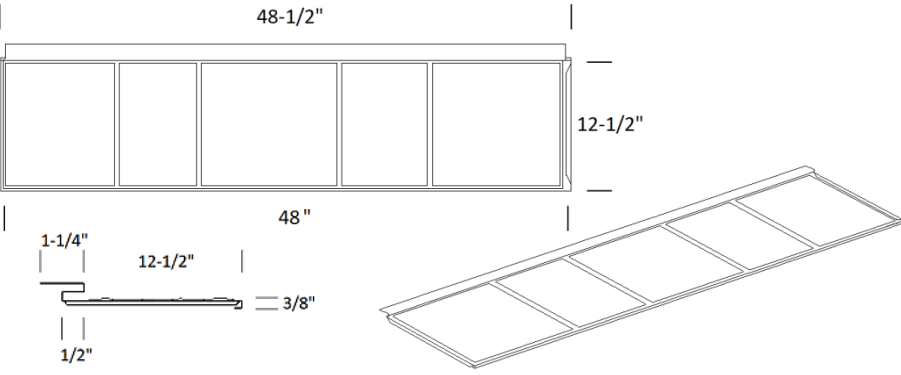

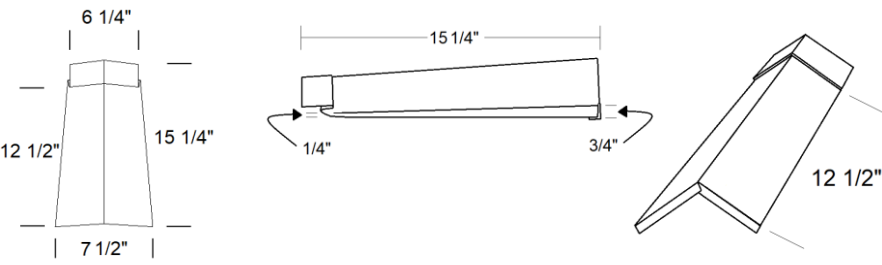
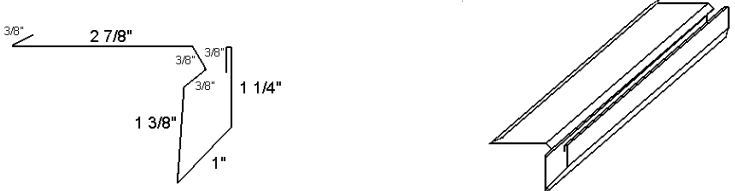
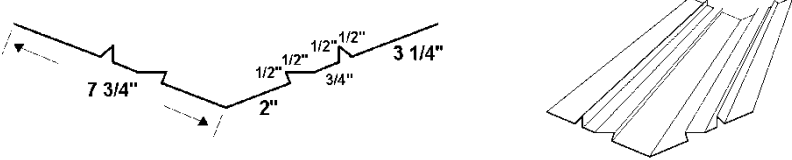

## IRONSTONE SLATE & FLASHING SPECIFICATIONS (2019)

	<p style="text-align: center;"><b>IRONSTONE SLATE</b></p> <table style="width: 100%; border-collapse: collapse;"> <tr><td>Overall Length</td><td style="text-align: right;">48 ½"</td></tr> <tr><td>Length of Coverage</td><td style="text-align: right;">48"</td></tr> <tr><td>Width of Coverage</td><td style="text-align: right;">12 ½"</td></tr> <tr><td>Total Panel Coverage</td><td style="text-align: right;">4.17 sq. ft.</td></tr> <tr><td>Weight</td><td style="text-align: right;">3.58 lbs</td></tr> <tr><td>Panels per box</td><td style="text-align: right;">20 pcs</td></tr> <tr><td>Panels per square</td><td style="text-align: right;">24 pcs</td></tr> <tr><td>Per pallet</td><td style="text-align: right;">22 bxs / 440 pcs</td></tr> <tr><td>Square per pallet</td><td style="text-align: right;">18.26 sq</td></tr> <tr><td>Weight per Pallet</td><td style="text-align: right;">1575 lbs</td></tr> </table>	Overall Length	48 ½"	Length of Coverage	48"	Width of Coverage	12 ½"	Total Panel Coverage	4.17 sq. ft.	Weight	3.58 lbs	Panels per box	20 pcs	Panels per square	24 pcs	Per pallet	22 bxs / 440 pcs	Square per pallet	18.26 sq	Weight per Pallet	1575 lbs
Overall Length	48 ½"																				
Length of Coverage	48"																				
Width of Coverage	12 ½"																				
Total Panel Coverage	4.17 sq. ft.																				
Weight	3.58 lbs																				
Panels per box	20 pcs																				
Panels per square	24 pcs																				
Per pallet	22 bxs / 440 pcs																				
Square per pallet	18.26 sq																				
Weight per Pallet	1575 lbs																				
	<p style="text-align: center;"><b>IRONSTONE CAP</b></p> <table style="width: 100%; border-collapse: collapse;"> <tr><td>Overall Length</td><td style="text-align: right;">15 ½"</td></tr> <tr><td>Length of Coverage</td><td style="text-align: right;">12 ½"</td></tr> <tr><td>Weight</td><td style="text-align: right;">0.9 lbs</td></tr> <tr><td>Slate Caps per box</td><td style="text-align: right;">50 pcs</td></tr> <tr><td>Boxes per pallet</td><td style="text-align: right;">12 boxes</td></tr> <tr><td>Slate Caps per pallet</td><td style="text-align: right;">600 pcs</td></tr> <tr><td>Weight per pallet</td><td style="text-align: right;">540 lbs</td></tr> </table>	Overall Length	15 ½"	Length of Coverage	12 ½"	Weight	0.9 lbs	Slate Caps per box	50 pcs	Boxes per pallet	12 boxes	Slate Caps per pallet	600 pcs	Weight per pallet	540 lbs						
Overall Length	15 ½"																				
Length of Coverage	12 ½"																				
Weight	0.9 lbs																				
Slate Caps per box	50 pcs																				
Boxes per pallet	12 boxes																				
Slate Caps per pallet	600 pcs																				
Weight per pallet	540 lbs																				
	<p style="text-align: center;"><b>IRONSTONE DRIP</b></p> <table style="width: 100%; border-collapse: collapse;"> <tr><td>Overall Length</td><td style="text-align: right;">96"</td></tr> <tr><td>Length of Coverage</td><td style="text-align: right;">93"</td></tr> <tr><td>Weight (6")</td><td style="text-align: right;">3.62 lbs</td></tr> </table>	Overall Length	96"	Length of Coverage	93"	Weight (6")	3.62 lbs														
Overall Length	96"																				
Length of Coverage	93"																				
Weight (6")	3.62 lbs																				
	<p style="text-align: center;"><b>IRONSTONE GABLE</b></p> <table style="width: 100%; border-collapse: collapse;"> <tr><td>Overall Length</td><td style="text-align: right;">96"</td></tr> <tr><td>Length of Coverage</td><td style="text-align: right;">93"</td></tr> <tr><td>Weight (8")</td><td style="text-align: right;">4.83 lbs</td></tr> </table>	Overall Length	96"	Length of Coverage	93"	Weight (8")	4.83 lbs														
Overall Length	96"																				
Length of Coverage	93"																				
Weight (8")	4.83 lbs																				
	<p style="text-align: center;"><b>IRONSTONE WALL</b></p> <table style="width: 100%; border-collapse: collapse;"> <tr><td>Overall Length</td><td style="text-align: right;">96"</td></tr> <tr><td>Length of Coverage</td><td style="text-align: right;">93"</td></tr> <tr><td>Weight (8")</td><td style="text-align: right;">4.83 lbs</td></tr> </table>	Overall Length	96"	Length of Coverage	93"	Weight (8")	4.83 lbs														
Overall Length	96"																				
Length of Coverage	93"																				
Weight (8")	4.83 lbs																				
	<p style="text-align: center;"><b>IRONSTONE 16" VALLEY</b></p> <table style="width: 100%; border-collapse: collapse;"> <tr><td>Overall Length</td><td style="text-align: right;">96"</td></tr> <tr><td>Length of Coverage</td><td style="text-align: right;">93"</td></tr> <tr><td>Weight (16")</td><td style="text-align: right;">9.66 lbs</td></tr> </table>	Overall Length	96"	Length of Coverage	93"	Weight (16")	9.66 lbs														
Overall Length	96"																				
Length of Coverage	93"																				
Weight (16")	9.66 lbs																				